

Inspection | Slitting | Rewinding

# VSI series

The Rotoflex VSI is the most widely used machine in traditional roll-to-roll label inspection, slitting and rewinding. It is known for its outstanding reliability in demanding production environments.

## Unique Benefits

- Unmatched defect detection and quality management
- Consistent output through automated tension management
- Precision slitting – efficient, accurate operation
- Easy to use – convenient, one-screen interface
- Most compact design – easy to access and operate
- Upgradable to meet future needs, including dual rewind, additional slitters and enhanced inspection

## VSI Features

### Genesis Advanced Control System

- Most advanced defect detection system available
- Full label length inspection
- Optimized label counting – multi-lane, various sizes & shapes
- MMLD – 100% matrix & missing label detection
- Precision fault placement
- Automatic set-up and sensor calibration
- Easy integration with peripherals such as Rotoflex exclusive LT Web Inspection System

### eDrive

- High performance web handling system with automatic tension control on both unwind and rewind
- Extreme web motion control delivers consistent quality on every roll
- Electronically synchronized integrated drive system provides lower tension and higher speeds
- Optimal acceleration and deceleration without compromising roll quality
- AC vector driven draw station and rewind with magnetic particle brake on unwind



**ROTOFLEX**  
LEADERS BY DESIGN

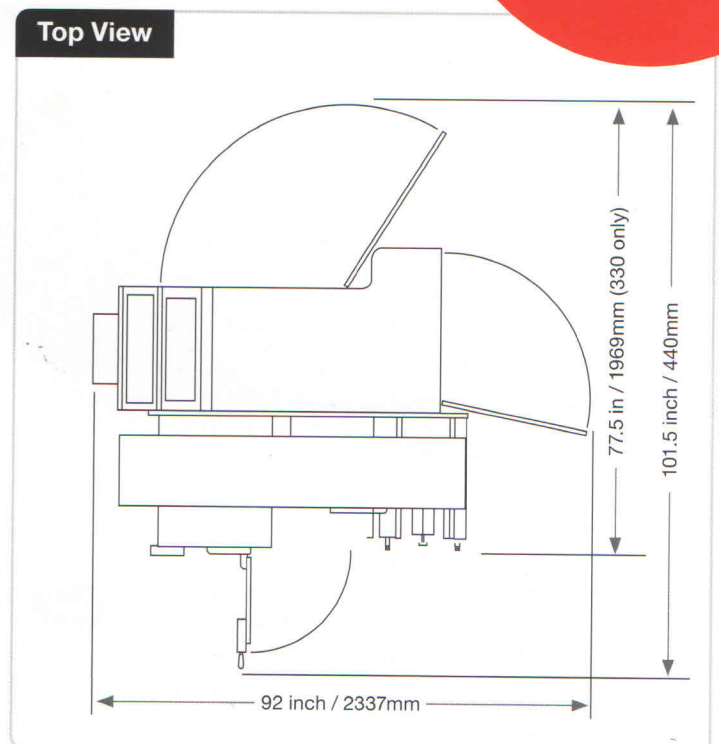
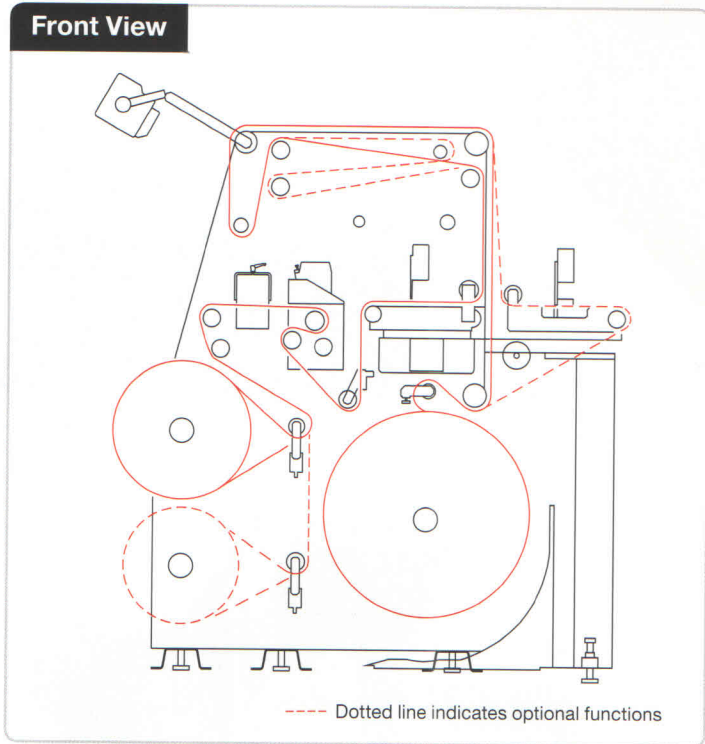

### Options

- Roll lift
- Slitters – crush knife, shear knife, razor and cartridge style
- Ultrasonic web guide sensor
- 40 inch / 1016mm unwind
- Auto web gripper/feeder
- Clear label count sensor
- Matrix & missing label detection
- Dual rewinds
- Strobe lights
- Horizontal unwind splicing table
- Web clamp
- Waste wind-up
- LT 100% Web Inspection Vision System
- Integration with complete range of inspection systems to meet any application need

### Specifications

	VSI330	VSI440
Web widths	13.25 inch / 337mm	17.25 inch / 440mm
Max unwind diameter	28 inch / 711mm	28 inch / 711mm
Max single spindle rewind diameter	18 inch / 457mm	18 inch / 457mm
Max dual spindle rewind diameter	16 inch / 406mm	16 inch / 406mm
Max speed	750 fpm / 230mpm	750 fpm / 230mpm
Draw station and rewind drive	AC vector	AC vector
Control system	Powered by Genesis	Powered by Genesis

### Configurations

- Basic label inspection/rewinding
- 100% Inspection/rewinding
- Advanced label inspection/rewinding
- Short run inspection

All Rotoflex equipment is backed 100% by MAX, the customer service and support arm of Mark Andy Inc. The largest team of technicians and parts specialists in the industry, Rotoflex users are supported with the knowledge and experience that only an OEM service team can provide. Visit MAX at [www.yourfriendinflexo.com](http://www.yourfriendinflexo.com)



#### Mark Andy Inc. World Headquarters

18081 Chesterfield Airport Road • P.O. Box 1023 • Chesterfield, MO USA 63006-1023  
 Tel +1 636 532 4433 Fax +1 636 532 1510 Email [info@markandy.com](mailto:info@markandy.com)

#### Mark Andy AG

European Headquarters  
 Tel +41 61 487 96 66  
 Fax +41 61 487 96 65

#### Mark Andy UK

Tel +44 1625 500964  
 Fax +44 1625 501334

#### Mark Andy France

Tel +33 1 64 60 39 90  
 Fax +33 1 64 60 39 99

[www.rotoflex.com](http://www.rotoflex.com)

**MARKANDY**